



www.raynendrive.com
 Customer Service Hotline: 400-0898-188

Raynen Makes Industry More Intelligent



RVE21 Series Variable frequency drive

Version: V24.12

Raynen® 睿能
 Raynen Technology Co., Ltd.

ADD: No. 12, Zhihui Avenue, Nanyu Town, Minhou County, Fuzhou, China.
 TEL : 86-591-88267288

The sample version is constantly updated with product upgrades, please pay attention to the version number
 For products and solutions marked with *, please contact us for detailed information

Raynen Technology all rights reserved ©

Stock Code (Raynen Technology 603933)

Raynen® 睿能

About Raynen

2007

Raynen Technology was established

Main Board Listing

Listed on the main board of Shanghai Stock Exchange in 2017

Stock Code: 603933

It is a high-tech enterprise specializing in the research and development, production, sales and service of industrial automation products.

Innovation Strength

The company is headquartered in Fuzhou, with nearly 20 subsidiaries and R&D centers in Shanghai, Wuhan, Fuzhou and Changzhou. It is a "Key High-tech Enterprise of the National Torch Program", "Fujian Provincial Enterprise Technology Center", "China Textile Machinery Industry Computerized Flat Knitting Machine Intelligent Control System Product R&D Center", "Fujian Textile Equipment Intelligent Control Enterprise Engineering Technology Research Center", etc. The company insists on driving the development of technology and products with scientific and technological innovation, and through years of accumulation, has formed a number of core technologies and patent technologies with domestic leading level.

Business Area

As a domestic technology-leading supplier of industrial automatic control products, Ruineng Technology focuses on the research of control and drive technology. After years of product and technology cultivation, it has completed the comprehensive expansion from industry-specific electronic control systems to general automation products. The company's general automation products include core products such as AC servo systems, frequency converters, programmable controllers, human-machine interfaces, and Internet of Things gateways. They are widely used in electronics, textile machinery, machine tools, printing and packaging machinery, logistics equipment, intelligent manipulators, woodworking machinery, laser processing equipment, metallurgy, petroleum, and chemical industries. It provides equipment manufacturing companies with competitive products and personalized solutions with leading technologies.

Mission and Vision

Raynen has always taken "making industry smarter" as its mission, adhering to "honest cooperation, open innovation, customer achievement, world-class intelligent industrial automation products and solutions suppliers, to achieve the common growth of enterprise value and customer value.



RVE21 Variable frequency drive

Product summary



The new member of the Raynen drive family, the RVE21 smart drive series, has a compact design, is exquisite and practical, has up to four control modes, and has an overload capacity of up to 200%. It can be widely used in the speed control of various asynchronous motors. The product relies on a 32-bit MCU and adopts the internationally leading vector control algorithm to achieve high-performance and high-precision motor drive control. While improving the reliability and environmental adaptability of the product, it strengthens the customer's ease of use and industry-specific design, with more optimized functions, more flexible applications, and more stable performance.

Product features

- Four control modes: constant torque V/F, quadratic load V/F, vector control without PG sensor, energy saving mode
- Compact design, exquisite and practical
- Overload capacity: 150% rated output current for 60s, 200% rated output current for 2s
- Built-in Modbus communication interface
- The panel can be externally connected, easy to use
- PCB coating to resist harsh application environments
- The side of the plastic shell product has a removable protective plate, which supports side-by-side installation
- High-performance vector control using flux and speed estimation technology
- Wide voltage range design ensures product adaptability to grid fluctuations
- Advanced independent air duct design, adaptable to various complex and harsh on-site environments

Product functions

Random carrier wave capability

- Compared with the sharp motor noise of the fixed carrier, the output voltage harmonic spectrum of the random carrier is evenly distributed in a wider frequency range, and the noise emitted by the motor is softer.

Instantaneous blackout protection

In case of instantaneous power failure or sudden decrease of input voltage, inertia energy of load side is fed back to DC bus by reducing motor speed to make up temporary energy gap, maintain DC voltage higher than undervoltage action value, and avoid shutdown due to undervoltage.

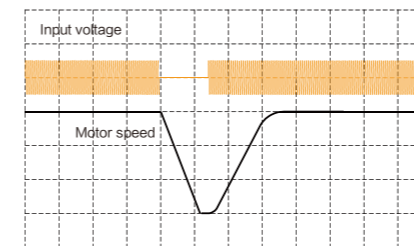

Quick Response

By improving the response speed and controlling the speed change during load disturbance, the motor speed can be kept constant to the greatest extent possible. Compared with traditional drives, the response time is shortened by more than half.

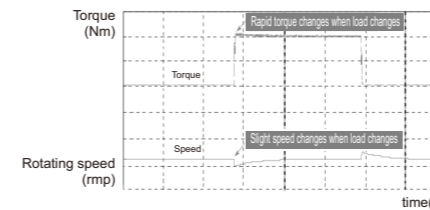

Reliable braking

- Magnetic excitation before starting, and then through frequency, current and other ways to open the brake to prevent the load slip;
- Before the stop, trigger lock brake in advance to ensure the stability of stop. Applications: Crane, Capstan.

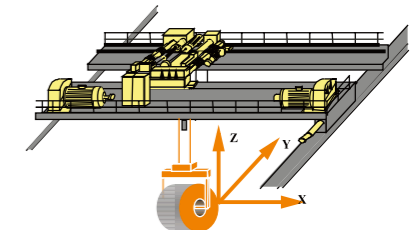

Wide voltage design

The input voltage fluctuation range is $-15\% \sim +26\%$ of the rated voltage, which can protect the device from the impact of voltage fluctuations and meet the harsh power grid environment.

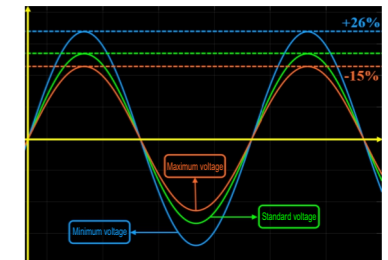

Excellent energy-saving function

The new generation of energy-saving control technology is adopted to achieve efficient operation of induction motors; reduce the excitation current according to the load current, and automatically adjust energy saving according to the load condition; maximize the motor efficiency; reduce motor loss and energy loss. 30% asynchronous motors and synchronous machines use vector mode to drive synchronous machines, and the energy utilization rate can be increased by more than 10%.

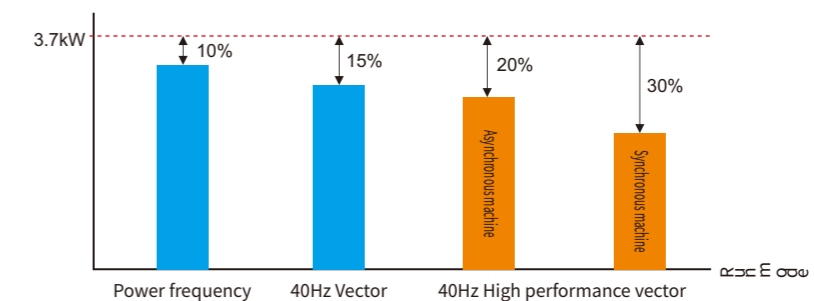

Multi-pump control function (non-standard program)

Using the built-in PID controller, multiple water pumps can be automatically switched on and off according to different pressures: the pumps can be rotated regularly to try to average the running time of each water pump; a dormant small pump can be set to ensure stable pressure at extremely low water consumption.

Note: Please specify this function when ordering

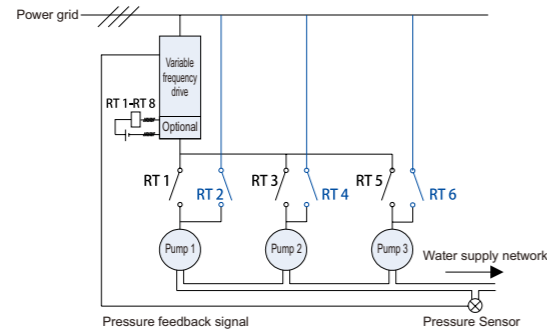

Software suppression function

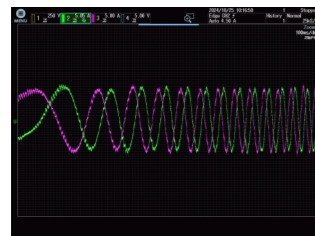

Overcurrent suppression

The current suppression function can prevent the drive from frequently giving out overcurrent alarms. When the current exceeds the current protection point, the overcurrent suppression function can continuously limit the current within the current protection point to protect the safety of the equipment and avoid overcurrent alarms caused by sudden load or interference. Reduce the losses caused by unwarranted shutdown.

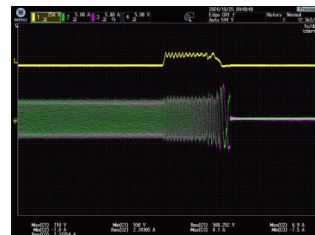

Overvoltage suppression

The overvoltage suppression function can prevent the drive from giving an overvoltage alarm during acceleration and deceleration. When the drive bus voltage reaches or exceeds the overvoltage protection point during acceleration and deceleration, the overvoltage suppression function can suppress the increase of the bus voltage by automatically adjusting the operating frequency, thereby protecting the equipment and avoiding the drive from giving an overvoltage alarm due to the increase of the bus voltage.

Application

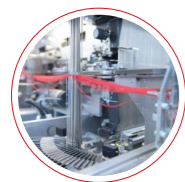

Textile printing & dyeing



Municipal environmental protection



Ceramic machinery



Food machinery



machine tool



Packaging machinery



Logistics equipment



Woodworking machinery



Fan and Water pump



Wastewater treatment

Product structure

EMC Design

With the surge current absorption circuit, can inhibit the surge current when the power input

Ac input reactor, AC output reactor or DC reactor can be selected to greatly reduce harmonic current

EMC filter is optional to reduce interference to external equipment and meet C2 international standards

Wide Voltage Input Range

Wide voltage input range in line with international standards, allowing appropriate voltage fluctuations

Rated voltage 3-phase 380-480V, 50Hz/60Hz

Allowable voltage fluctuation range: 323V-506V, 50Hz/60Hz

Long Life Design

The key components are all made from the industry's first-class manufacturers, with long design life

Strong and Weak Electrical Isolation Design

Adopt strong & weak electrical isolation Design, to avoid magnetic field interference and increase service life.

Three Anti-paint Automatic Spraying Process

Three anti-paint automatic spraying equipment, according to the layout characteristics of the circuit board programming spraying path, to ensure that the coating is comprehensive, uniform, good consistency. Thickened coatings can be ordered for use under particularly harsh conditions

Thermal design and thermal reliability

Independent air duct: including IGBT, rectifier bridge, electrolytic capacitor

Above 25Hz, it adopts low loss design. Peak and trough of wave 1/6 cycle non-chopper to enhance local heat dissipation design

Parts strictly adopt international standards, type test main test content

Details	Absolute allowable temperature
Transformer, IC, rectifier bridge	125 °C
Electrolytic Capacitors	95 °C
Contactors	130 °C
PCB	120 °C
Charging resistor	180 °C
IGBT heat sink	85 °C

VFD Temperature test: 40 °C

Exfactory aging test: high temperature 60 °C

Heat Dissipation Structure

Independent cooling duct optimization design, from the original right angle optimization to rounded corner, reduce the thermal disk accumulation, greatly increase the efficiency of heat dissipation.

Fan quick disassembly/assembly design

The innovative fan structure design ensures the fan's stability and efficiency, and enables the fan to be quickly replaced and cleaned without the need for external tools.



Model description

RVE21 - T3 - 7R5 G / 11 P - E
 ① ② ③ ④ ③ ④ ⑤

① Product Series RVE21: Raynen VFD Export	② Supply Voltage S2: single-phase 220V T3: Three-phase 380V	③ Adapted motor power 0R4 : 0.4kW 0R7 : 0.75kW 1R5 : 1.5kW 2R2 : 2.2kW 710 : 710kW 800 : 800kW
④ Load Type G: Overload P: Light load	⑤ Motor Type None: Asynchronous motor E: Permanent magnet synchronous motor	

Appearance size

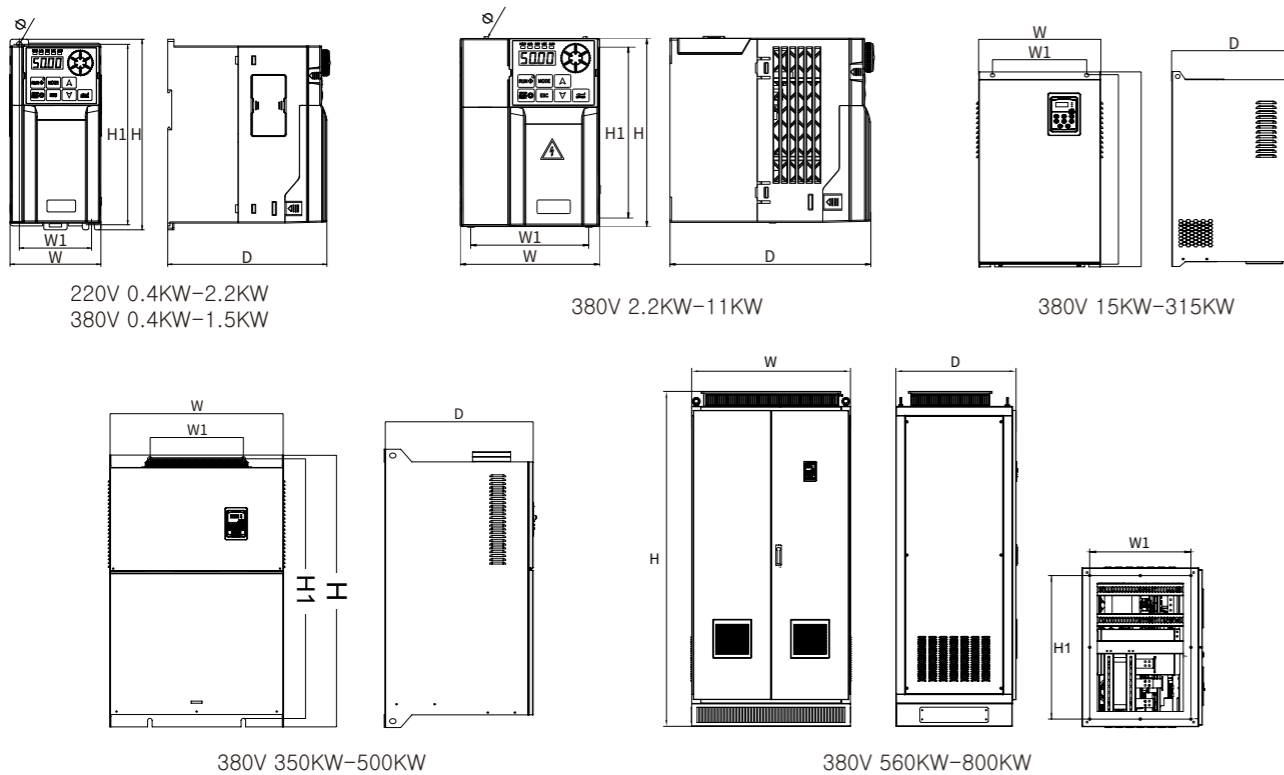

Model selection

Model (single-phase S2)	Adaptive motor (kW)	Rated input current (A)	Rated output current (A)	Overall dimensions(mm)			Installation Dimensions(mm)		
				H	W	D	H1	W1	Aperture
RVE21-S2-0R4	0.4	6.3	2.5	170	81	142	161	64.5	Φ5
RVE21-S2-0R7	0.75	11.5	5						
RVE21-S2-1R5	1.5	15.7	7						
RVE21-S2-2R2	2.2	27	10						

Model selection

Model (three-phase T3)	G Type (Heavy load)			P Type (Light load)			Dimension (H*W*D mm)	Installation size (H1*W1 mm)	Aperture
	Motor power (kW)	Rated input current(A)	Rated output current(A)	Motor power (kW)	Rated input current(A)	Rated output current(A)			
RVE21-T3-0R4G/0R7P	0.4	2.1	1.5	0.75	3.6	2.6	170*81*142	161*64.5	Φ5
RVE21-T3-0R7G/1R5P	0.75	3.6	2.6	1.5	6.4	4.1			
RVE21-T3-1R5G/2R2P	1.5	6.4	4.1	2.2	8.7	5.5			
RVE21-T3-2R2G/3P	2.2	8.7	5.5	3	10.9	6.9	145*107*160.4	135*95	Φ5
RVE21-T3-3G/4P	3	10.9	6.9	4	14	9.5			
RVE21-T3-4G/5R5P	4	14	9.5	5.5	20.7	12.6	200*138*144.6	188*124	Φ5
RVE21-T3-5R5G/7R5P	5.5	20.7	12.6	7.5	26.5	18.5			
RVE21-T3-7R5G/11P	7.5	26.5	18.5	11	36.6	25	232*153*169.8	220*139	Φ5
RVE21-T3-11G/15P	11	36.6	25	15	40	32			
RVE21-T3-15G/18P	15	40	32	18.5	47	38	327*168*185.6	313*120	Φ9
RVE21-T3-18G/22P	18.5	47	38	22	56	45			
RVE21-T3-22G/30P	22	56	45	30	70	60	335*200*195	321*140	Φ9
RVE21-T3-30G/37P	30	70	60	37	80	75			
RVE21-T3-37G/45P	37	80	75	45	94	92	410*260*214	396*180	Φ9
RVE21-T3-45G/55P	45	94	92	55	128	115			
RVE21-T3-55G/75P	55	128	115	75	160	150	520*288*236	500*200	Φ11
RVE21-T3-75G/90P	75	160	150	90	190	180			
RVE21-T3-90G/110P	90	190	180	110	225	215	600*310*310	583*240	Φ11
RVE21-T3-110G/132P	110	225	215	132	265	260			
RVE21-T3-132G/160P	132	265	260	160	310	305	720*355*345	698*240	Φ13
RVE21-T3-160G/185P	160	310	305	185	355	350			
RVE21-T3-185G/200P	185	355	350	200	385	380	920*480*390	898*320	Φ13
RVE21-T3-200G/220P	200	385	380	220	430	425			
RVE21-T3-220G/250P	220	430	425	250	485	480	1100*480*405	1078*320	Φ13
RVE21-T3-250G/280P	250	485	480	280	545	530			
RVE21-T3-280G/315P	280	545	530	315	610	600	1100*650*465	1060*350	Φ17
RVE21-T3-315G/355P	315	610	600	355	665	650			
RVE21-T3-355G	355	665	650	-	-	-	2200*1100*800	943*665	Φ16
RVE21-T3-400G	400	785	725	-	-	-			
RVE21-T3-500G	500	890	860	-	-	-	2200*1400*800	1100*665	Φ16
RVE21-T3-560G	560	950	950	-	-	-			
RVE21-T3-630G	630	1100	1100	-	-	-	2200*1400*800	1100*665	Φ16
RVE21-T3-710G	710	1280	1280	-	-	-			
RVE21-T3-800G	800	1380	1380	-	-	-			

Note: If the product is used for permanent magnet synchronous motor, please add code "E" to the order model.

External lead panel

Plastic shell panel

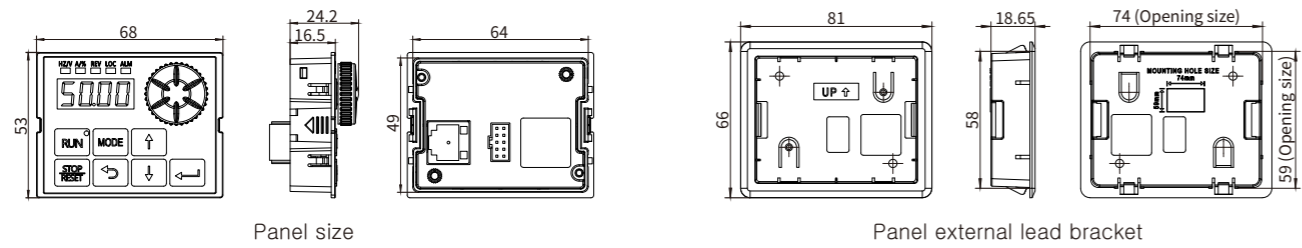

Iron shell panel

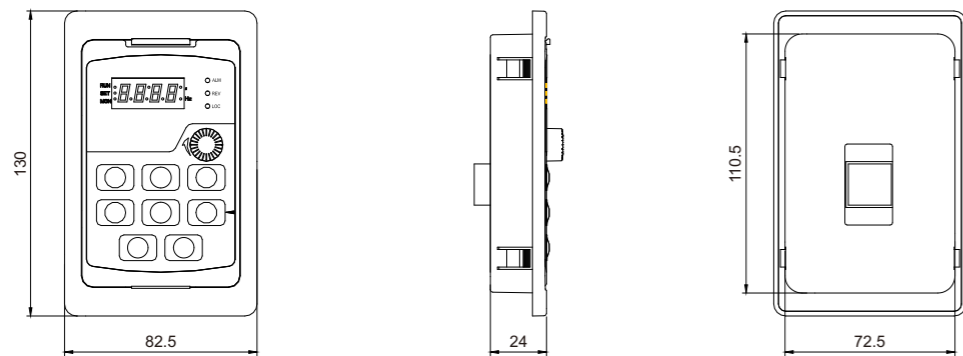

Schematic diagram of control terminal structure

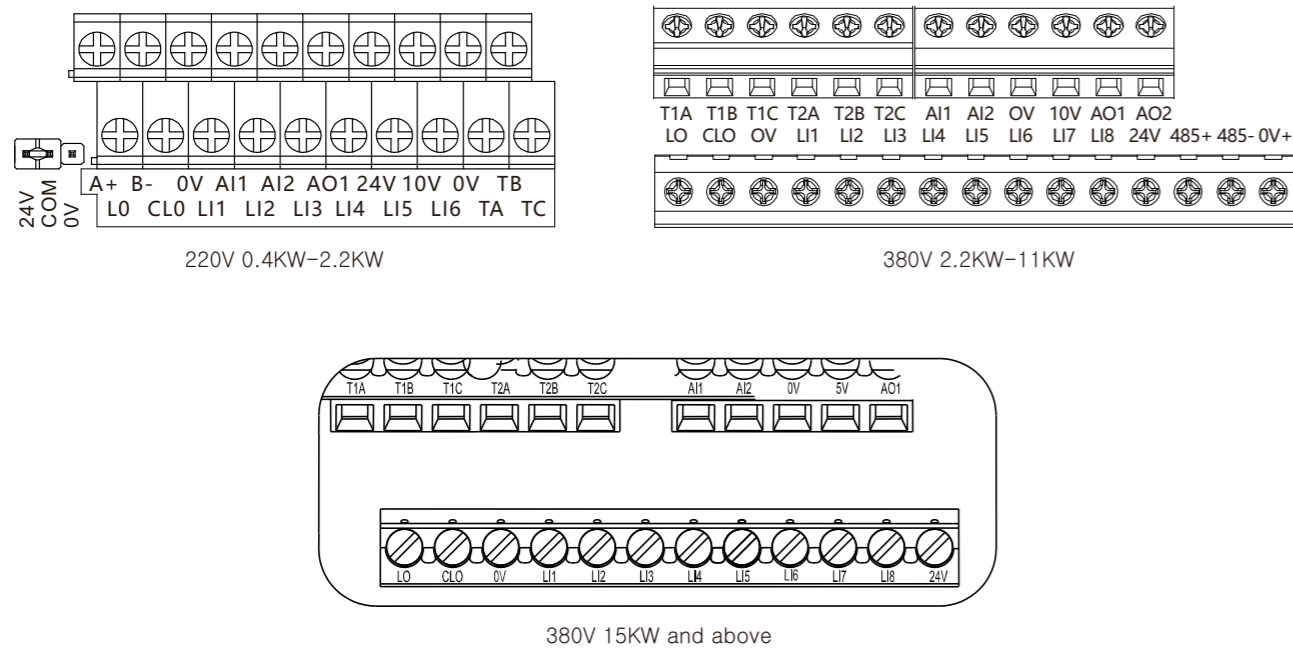

Standard wiring diagram

RVE21 series 380V (T3) 2.2kW~11kW

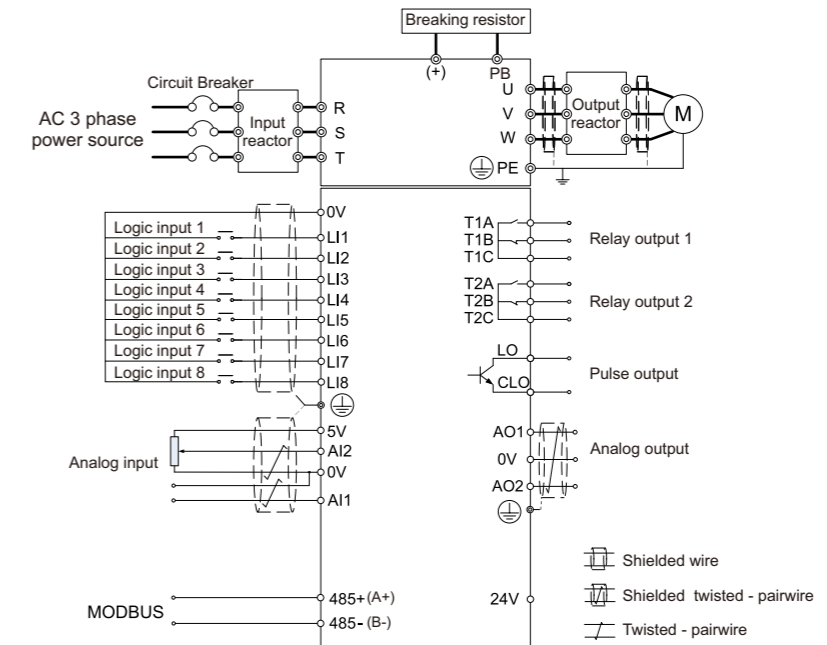

RVE21 series 380V (T3) 15kW~800kW

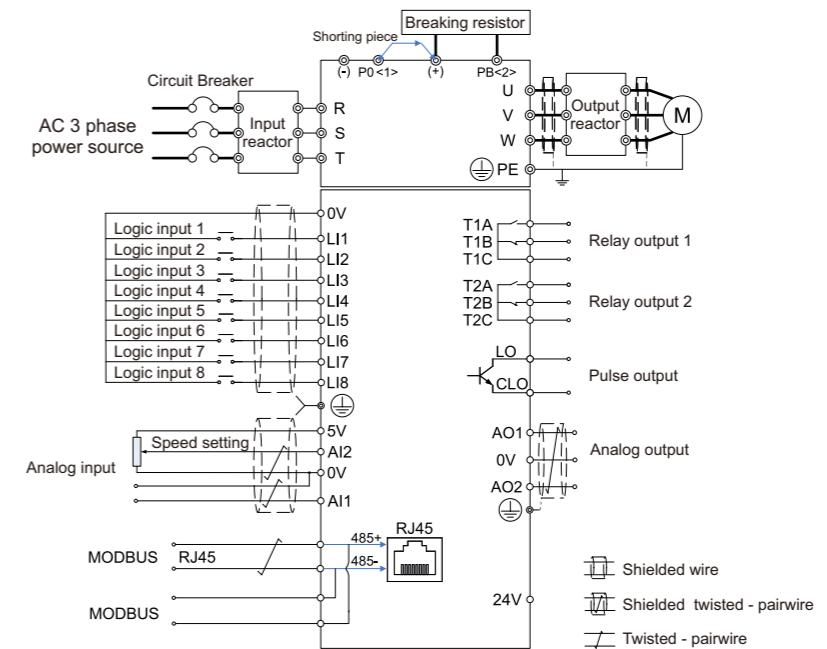

<1> The 15kW drive does not have a P0 terminal: for drives above 45kW (inclusive), be sure to remove the short-circuit between P0 and (+) when installing the DC reactor (optional).

<2> The 15kW drive has a PB terminal, and a brake resistor can be connected between PB and (+).

Note: The figure shows the standard wiring diagram of some models of RVE21 series. Please consult customer service for standard wiring diagrams of other power models.

■ Performance & configuration

Basic application functions	
Low frequency torque boost	The voltage boost and torque boost can increase the low-frequency torque of V/F control and speed sensorless vector control by about 0.1%~30.0% respectively.
V/F Curve	Linear type, multi-point type
Acceleration and deceleration curve	Linear or S-shaped acceleration and deceleration; three sets of acceleration and deceleration time; acceleration and deceleration time range: 0~3200s
Automatic Voltage Regulation (AVR)	When the grid voltage changes, it can automatically keep the output voltage constant
Built-in PID	Closed-loop control system that can easily realize process control
DC braking	DC braking range: 0.0Hz~maximum frequency; braking time: 0.0s~20.0s Braking action current value: 0%~100%
Jog control	The motor can be started and stopped immediately; the inching frequency setting range is: 0.0~20.0Hz Inching stop mode: deceleration/free/DC braking
Frequency Hopping	You can set 3 frequency hopping points and the corresponding frequency hopping range to prevent the drive from running within the frequency band.
Multi-speed	Up to 15 operating frequencies can be set via 4 logic input ports
Input Sum	The algebraic operation result of 2 analog inputs is used as the frequency setting, making the frequency setting more flexible
2 sets of motor parameter switching	Two sets of motor parameters can be set and switched freely to match the currently driven motor
Drive protection	Input/output phase loss protection, underload detection, over-torque protection, undervoltage protection, overvoltage protection, overcurrent protection, overheating protection, phase short circuit protection
Motor protection	Motor thermal protection, motor current limiting, motor overload, motor short circuit

Electrical characteristics	
Input voltage	Three-phase AC, 380~480V, 50/60Hz or single-phase AC, 200~240V, 50/60Hz
Output voltage	0~100% input voltage, 0.5Hz ~ 400Hz
Control Mode	Constant torque V/F, quadratic load V/F, sensorless vector control, energy-saving mode
On-off level	1.5kHz ~ 12kHz The automatic switching frequency adjustment function can be set: when the temperature rises, the switching frequency is automatically reduced After the temperature returns to normal, the switching frequency returns to the initial value
Overcurrent capability	150% rated output current for 60s, 200% rated output current for 2s

Control signal		
Frequency setting signal	Integrated operating panel	Membrane switch (button), speed knob (potentiometer)
	External Signal	UP/DOWN setting, analog input, multi-speed, external panel, serial communication
Start-stop control signal	Integrated operating panel	RUN, STOP buttons
	External Signal	Logic input terminal, external panel, serial communication

Protective function	
Drive protection	Input phase loss protection, output phase loss protection, underload detection, over-torque protection, undervoltage protection, overvoltage protection, overcurrent protection, overheating protection, phase short circuit protection
Motor protection	Motor thermal protection, motor current limiting, motor overload, motor short circuit

Control circuit characteristics		
Internal power supply available	10V 24V	10VDC ±5%, maximum current 10mA, for reference potentiometer 24VDC ±5%, maximum current 100mA, for logic input port
Analog Input	AI1	Voltage analog input: 0~5VDC, or 0~10VDC, impedance 30k Current analog input: 0/4~20mADC, impedance 250Ω Resolution: 10-bit A/D conversion Factory default setting: 0~5VDC voltage input
	AI2	Voltage analog input: 0~10VDC, or PTC probe input Resolution: 10-bit A/D conversion
Logic Input	LI1-LI8	0~24VDC power supply Positive logic (source), negative logic (sink) are optional, the factory default is negative logic 69 functions are available, including forward, reverse, running, fault reset, multi-speed, etc. 220V 0.4kw~2.2kw and 380V 0.4kw~0.75kw products only have 6 circuits: LI1-LI6
	AI1, AI2 Enforce valid input	In drives below 11kW (inclusive), AI1 and AI2 can be set as logic inputs. f309 and f310 are mandatory valid inputs, and their configuration functions are always valid during power-on.
Analog Output	AO1, AO2	Voltage analog output: 0~10VDC, minimum load impedance is 470Ω Current analog output: 0/4~20mA, maximum load impedance is 700Ω Resolution: 8 bits Output frequency, output current, speed setting, serial output data Multiple functions available 220V 0.4kw~2.2kw and 380V 0.4kw~0.75kw products only have 1 analog output, namely AO1
Logic Output	LO, CLO	Open collector, maximum current 100mA, maximum voltage 30VDC Logic output or pulse output is optional, the factory default setting is logic output Output frequency, output current, speed setting and other output functions are optional
Relay output	T1A, T1B, T1C T2A, T2B, T2C	T1A is normally open, T1B is normally closed, T1C is a common point T2A is normally open, T2B is normally closed, T2C is a common point Contact rating: 5A @ 250VAC, 5A @ 30VDC Fault, alarm, set frequency arrival and other functions are optional T1A defaults to failure, T2A defaults to operation 220V 0.4kw~2.2kw and 380V 0.4kw~0.75kw products only have 1 relay output, namely TA-TB-TC
Serial Communication		MODBUS-RTU, 2-wire RS-485, terminal interface

Environmental characteristics			
Protection level	IP20	environment humidity	95% no condensation or water accumulation
Working temperature/storage temperature	-10~40℃ /-20~60℃	Altitude	Below 1000m
cooling method	Forced air cooling	Installation location	Indoor